

**Project Case Studies**  
St Pancras International  
Station  
Page 5



**Porsche Supercup Update**  
Team SAS reports from Bahrain, Spain, Istanbul and Monaco  
Page 8



**Design Competition**  
Architects 4 Aid has rebranded as Article [25], leading architects are auctioning jelly designs and moulds in aid of Article 25  
Page 3



# INSIDER

Metal Ceilings • Partitioning • Room Comfort • Architectural Metalwork

July 2008 Issue 7

## New SAS 'International White' Tee Grid

SAS International Exposed Tee Grid is now available in 'International White'.

The range comprises of 38mm deep main runners and cross tees which are roll formed using galvanised steel and a wet painted capping.

Available in widths of 15mm (T15) and 24mm (T24), with main runners lengths in 3000mm (3m) and 3600mm (3.6m). Butt cut or joggled end detailing is available on all cross tees.



SAS International will guarantee all ceiling tile products used with SAS Tee Grid providing the ceiling has been installed in accordance with:

- BS EN 13964:2004 Suspended Ceilings, Requirements and test methods.
- AIS (Association of Interior Specialists) Guide No1. Good Practise For The Installation Of Suspended Ceilings.

For further information and guidance please contact us.

### SAS Tee Grid Features

- Easy to install
- Strong Modular Appearance
- Double Stitched for strength and rigidity
- Flexible Punching centres for ceiling modules
- Butt Cut or Joggled end options
- Compatible with all T15 and T24 lay in ceiling tiles
- Cross Tee depth of 38mm ensures strength and rigidity

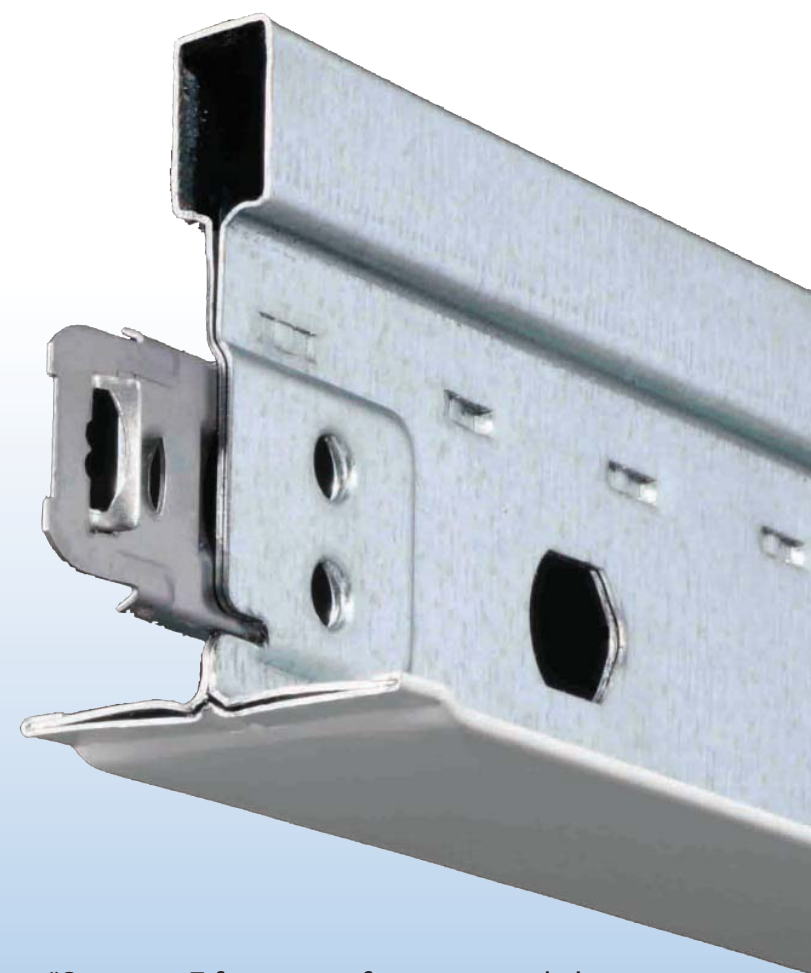

\*See page 7 for more information and photos

## Apollo Park Extension and Launch

SAS Apollo Park have completed Phase 2 of building works on time and to budget.

The extension of the factory that opened in 2007 took six months to complete. All machinery for the manufacturing of the SAS door product is now under one roof.

An opening morning for invited guests took place on the 1st July 2008. Team Lechner SAS was on hand with Porsche Supercup drivers Damien Faulkner and Danny Watts who gave guests an insight in to racing in the Porsche Supercup.



Team SAS and Apollo Park in Pole Position  
Tuesday 1<sup>st</sup> July 2008

## AIS Gold Award for SAS Project Management



On the 11th June SAS Project Management won the AIS Gold Award in the Special Judges' Category for the unusual and complicated installation at the Alea Casino, Glasgow



The Award was presented at the Association of Interior Specialists President's Lunch at The Dorchester in London.

The judges commented: "The design concept behind this entry could be characterized as 'off the wall', the solution devised by the entrant could be described as inspired. It's not a ceiling, it's not a wall – it's a huge, at first glance free floating, 'wave' transcending three floors".

Congratulations to all in SAS Project Management

## Every quarter a representative from an area of the SAS Group reports on Company activities, important news and what to look out for in the forthcoming quarter.

In the past few weeks SAS has received a £1.75m order from Doha in the Middle East to supply architectural cladding to air supply ductwork in the new Al Shaqab Equestrian Academy in Qatar.

As a horse lover, the Emir of Qatar is building a huge state-of-the-art equestrian facility consisting of an indoor and outdoor performance arena and a series of associated stables.

In the summer months in Qatar the shade temperature reaches 50°C regularly, so there is an essential requirement to air-condition the stable building.

SAS proposed a design solution that support to the air supply and return ductwork, provides a polyester powder coated aluminium cladding solution (to conceal the ductwork) and allows for the integration of the lighting, air grillers, cable trays and PA systems.

Our manufacturing capabilities and skills in design combined with evidence of our previous projects contributed to SAS being awarded the contract.

Combining the manufacturing skills of all three factories, we had the design complete and prototypes installed in Reading within 5 weeks and soon after hosted a successful inspection by the client, architect and contractor. The prototypes have since been installed in Doha and await final approval.



Al Shaqab Academy

Manufacturing is due to commence in July and to be completed by the end of September. We are contracted to supply cladding to two ducts with approximately 11,585sq.m of finished product. It's going to be a busy summer.

**Jon Wood**

The quarter has again been very busy in terms of generating new business opportunities.

Over in Ireland we have recently put bids in for two major projects, one for Anglo Irish Bank and the other for Dublin's new Terminal at the airport. We have been busy servicing small orders from our stock of commodity products at our premises in Blanchards Town.

This has been a welcomed service to local contractors who are able to pick up products at the drop of a hat!

We would like to welcome two new members of staff to the sales team. Hannah Faithful who is looking after the sales of our new Tee Grid and Andrew Crosby who is developing our doors and partitioning business. We wish them every success with their roles.

Both positions come at an extremely exciting time in Sales. With our new roll forming lines at Bridgend and our new veneering line at Apollo Park, we have many new products that we now able to offer our customers.

Over the coming months you will see a lot of activity in chasing business from project opportunities that we not been able to touch because the ceilings have been mineral as opposed to metal.

Now with our new roll forming lines we are able to offer T24 and T15 grid to go with mineral tiles at the most competitive of rates.



Hannah Faithful



Andrew Crosby

**Phil Smith**

Quarter 2 of 2008 is very busy. The new Metal Ceiling brochure was released to the market. Everyone seems to be impressed with the format and the information contained in it. Thanks to everyone internally who contributed. As you have seen from the front page Apollo Park Phase 2 is complete and as I write we are preparing for the launch.

The first time SAS International has opened its factory doors for an official event since the Bridgend opening in 1989. The factory looks incredible. Steve and all at Apollo Park have done an awesome job. With the partitioning and particularly doors resource realised we continue to target these markets supporting Andrew Crosby.

SAS Tee Grid is also being launched and product information has been produced to support Phil and Hannah's efforts with potential customers. Look out for this in the next few weeks.

This quarter saw Team SAS on the podium twice in the Supercup. 1st in Bahrain and 2nd in Monaco. Over 30 guests have attended the racing so far this year. The SAS website, Room Comfort and Architectural Metalwork brochure are all on the way. However, the big news this quarter is both Malcolm and John have presented over 30 CPD's to over 300 people year to date!

See page 4 for additional information.

**Andrew Jackson**

The past few months have seen a high demand for all ranges of the Maybole product from standard System 330 Grid to bespoke metalwork solutions for projects such as Manchester Airport (wall cladding/stainless steel skirting) and Hills Place Integrated Service Modules (ISMs).

We successfully passed our BSI re-assessment for ISO 14001 and are preparing for our ISO 9001 re-assessment in the first week of July. We have spent the period getting used to the new Syteline system.

With regards to our on-going expansion plans, soil testing will be undertaken during July 2008 at the proposed development site. Findings will dictate the suitability of the land for development, so a decision can be taken later this year.

On 4th July 2008 one of our employees, John Skilling Senior will attend the Silverstone Grand Prix weekend as the representative from Maybole. John has worked for SAS for nearly twenty years and is officially past retirement age but still contributes four days per week working alongside his grandson Jordan (Production Operator) and supported by his son John (Jordan's dad) who is a Production Engineer.

Forecast levels for the business remain very positive with some large projects imminent for Quarter 3/4. The last six months of 2008 look to be as busy and productive as the first six for everyone at SAS Maybole.

**John Gemmell**

Project Management has commenced several new projects in the second quarter of this year, most of which are active Integrated Services Module (ISM) projects. Three projects are in London at Hills Place, W1 for Clarendon Properties; Places For People in Grays Inn Road; and the London School of Hygiene and Tropical Medicine in Gower Street. By far the largest project, awarded to PM by the Midas Group, is the refurbishment and extension to commercial offices in Greyfriars, Bristol for client the Borough of South Tyneside Pension Fund which has a value in excess of £1.5 million.

The interest from clients and developers in the active and passive comfort heating and cooling market continues to increase, and we are currently negotiating or at the design stage of producing mock ups for several further projects in the south of England. The Irish market is still busy, we are currently working on a major project in Dublin for developer Danninger Estates worth approximately 4 million euros.

SAS Project Management has been recognised for our experience and ability to design and install very special architectural metalwork projects with a prominent



Maggie's Centre, Hammersmith

article in the 'Building' magazine for the roofing and soffit linings package at the Maggie's Centre project at Hammersmith. We were also awarded the AIS Contractors' Gold Award in the special Judges Award category for the wave ceiling installation at the Alea Casino at Springfield Quay, Glasgow: the PM profile is increasing.

Project Management welcomed John Proctor as contracts manager and Suzanne Speller as estimator, who both joined the PM team in the quarter.

**David Bland**

After a relatively quiet first quarter, Avanti's business has increased in April and May. This combined with the current order book gives us confidence for the coming months. Products such as Fireshield and Matrix (System 2000 and 3000) have increased in popularity within the specification market. Designer, Solare and Unity are starting to show the benefit of considerable effort from the new specification sales force.

The integration of Avanti with SAS is moving forward with both our Fireshield and Matrix products being bought solely from Apollo Park. At present the move towards all products being painted at Apollo Park is well advanced with a target of 100% being set for July.

Steve Horner and his team have assisted in the supply of our largest export project and are also currently working on the Unity frames for the Audi/Sytner project that was mentioned in the last issue.

Avanti have also been contributing to SAS by winning of two metal ceiling orders, the first with System 130 and the second a special tile order.

Finally, in March, we had our annual audit for ISO 9001 which we passed with flying colours.



**John Birken**

# New Name for A4A - article [25]

development + disaster relief



Barjas 'Jelly' Airport Rogers Stirk Harbour + Partners

Architects for Aid was renamed to Article 25, Development and Disaster Relief on the 1st June 2008. Article 25 of the Universal Declaration of Human Rights is the only article referring to the built environment and states that adequate shelter and dignified housing is a fundamental human right. Our projects involve all facets of the built environment with a diverse mix of volunteers. While we are proud of our architectural foundations, the new name reflects not only our growth over the past 2 years but our continued commitment to the built environment.

*At Home...*

We are very proud to be the official charity of the London Festival of Architecture 2008. The month long event has over 600 events celebrating and exploring open spaces, streets and buildings all over the capital.

As part of the event a[25] has teamed up with legendary designer Paul Smith to create an exclusive t-shirt.

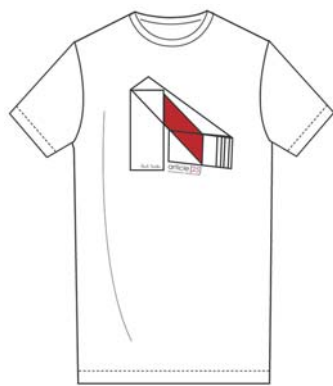

The T-Shirts are priced £39 each, if you wish to order one please email insider@sasint.co.uk.

The highlight of our fundraising efforts is in the shape of the Bompas & Parr Architectural Jelly Banquet where the winner of the Architectural Jelly Design Competition will be announced. The short listed designs and moulds will be auctioned off in aid of Article 25, the full shortlist includes entries from Atkins, Foster + Partners, Grimshaw, Tomkin Liu and Rogers Stirk Harbour + Partners.

*In the field...*

In the past Issues we have been following the progress of the LCCU in Lesotho, you will be glad to hear that it is now complete, despite burning down twice. Pedro Clarke, a[25] volunteer was on the ground for over a year overseeing this project.

In Pakistan, Sam Woodbridge has been managing the construction of seismic resistant housing for the most vulnerable victims of the 2005 earthquake.

In May, a prototype of a new construction structure for the Kyomya East Sponsorship project in Uganda (profiled in Issue 6)



took place at Nottingham University. The result was a single bay of a double skinned parabolic structure, 1.2m in width. A number of these bays can be constructed and connected to make a building, a hospital or school in Uganda. Using this structure on site, it is estimated that a school can be constructed in roughly 4 weeks.

In July a small team will be conducting a feasibility trip to Sierra Leone where a[25] is collaborating on a school project with Foster + Partners and partner charity Save the Children.

Article 25 could not continue the work we do without the support of our sponsors. Thank you to all at SAS who support our name change and the valuable free expertise we provide to partner Non Government Organisations all over the world. Thank you for enabling us to build better wherever there is disaster, poverty or need.

**Lisa Dayanandan**  
Office Manager, article [25]

[www.article-25.org](http://www.article-25.org)

## Avanti's Royal Appointment

It's not everyday an invitation to a Royal Palace lands on your desk.

The invitation came via Action Medical Research, the charity Avanti have been sponsoring for the past 3 years. Through our annual charity golf days Avanti have raised in excess of £50,000 for Action Medical Research.

Because of Avanti's continued support we were invited to become Action Partners. 10 Action Partners were invited to a reception at St James Palace to meet HRH Prince Phillip the Duke of Edinburgh who is the charities's patron.

Attending from Avanti were Barry Bates, Managing Director and his wife Jocelyn, John Birken, Commercial Director and Beverley Toms, HR Manager.



HRH Prince Philip the Duke of Edinburgh, John Birken & Beverley Toms

The reception was attended by doctors, research scientists and teams of people who use donations to work on such things as developing ultra sound, used in the early stages of pregnancy, and the importance of folic acid in our bodies.

We all accept these medical discoveries and don't question how they come about; this was our chance to actually meet the people behind the scenes, the people that make the difference.



**Beverley Toms**  
Avanti Systems

## SAS Girls Use Pedal Power

Thank you to everyone for supporting us to take part in the London to Brighton Bike ride this year.

The weather on Sunday the 16th June was perfect and we all had a fab time. The 54 miles were definitely a challenge, but we completed it and are really pleased with our efforts.

I'd love to say it was in a record time but you know I'd be lying so I'll say that we all pushed ourselves hard and really earned our medals.

More importantly we have a really significant sum of money pledged (£1000) to give to the British Heart Foundation to help combat heart disease and that is down to all of your kind contributions.

We've had such a good response it would be great to collect it all ASAP. Louise has



Sarah De Bank, Martin England, Andrea Nightingale, Lorraine Knight, Diane Broomfield & Lindsay Murgatroyd

the form if you can't remember how much you pledged, or if you forgot to donate at the time she can collect all monies!

On behalf of the SAS girls, thank you, thank you, thank you for making our efforts worthwhile.

**Sarah De Bank**  
SAS Reading

## September Price Increase

We recently made you aware of steel price increases which resulted in a 13% increase on the 1st July. (Issue 6)

Our steel suppliers are now imposing a further increase. A further increase will be applied to cusotmoers on the 1st September of 9%.

Due to our current material stockholding you will notice that we have been able to delay the impact of the increase. All increases are applied to product despatched and invoiced after these dates -not order date.

For further information please contact jbullock@sasint.co.uk

## Caldicot Under 15's Rugby Club

I've been coaching this side since they were formed as an under 8's rugby side in 2000. The squad of 28 players made up of both local and boys from Newport and Lydney.

We play fixtures throughout South Wales and Bristol & Gloucester and regularly attend festivals in Newbury and London Saracens and have gone on tours in Ireland, England and Scotland.

This season's tour was in North Wales and whilst "What goes on Tour stays on Tour", the whole squad were last seen "bonding" in a local disco 2 o'clock in the morning on the day of the game. As a club we insist that after each game home or away every squad member wears a shirt and club tie, SAS kindly initially sponsored our shirts in 2005. However, the boys quickly outgrew them so we appreciated it when once again SAS offered to sponsor the team again.



**Simon Webb**  
SAS Bridgend

# Metal Ceilings System Brochure Launched

The new metal ceilings brochure is now out in the market being tried and tested by customers and specifiers alike. Having spent the first weeks of June ensuring that over 3,500 copies have gone out to the appropriate contacts, there has been fantastic feedback from SAS staff and literature users.

The brochure is being promoted on three industry websites in the forms of banner advertising. Please remind the market that we have updated our information and offer them an updated copy.

A metal ceiling 'flyer' was inserted in 'Building' magazine during June, in addition these 'Flyers' are going out with all Reading delivery notes and quotations.



## New SAS ISO Logo

A new ISO logo is being used across the group. As the development of ISO standards continue, the way we communicate within the industry is changing too. Previously we had two different logos for the ISO 9001 and 14001 accreditations.

This has now changed to one logo that reflects both standards. All material requiring the update will be worked through by marketing as required.



FM 504171 FM 23840 FM 54954 ISO 9001  
EMS 504170 EMS 508066 ISO 14001

## SAS In the News

Two articles have recently been published in major UK magazines. 'The Architects Journal' highlighted the Dublin's office recent System 600 work at the Commissionaire of Irish Lights. 'Building' ran a three page article on the Architectural Metalwork installed at Maggie's Centre, London.

Marketing would like to thank both Cathal McGuinness and Richard White for their help in putting these article together. If you would like a copy of the articles please contact the marketing department.



## New Case Studies 2008

There is always an interesting project to cover with a case study. Many staff feel that projects that they have worked on are "too small" to cover. In reality it's the application not necessarily the size of the project that interest people.

Recent architectural metalwork projects installed by SAS Project Management are currently being worked on. If you require copies of case studies or would like to suggest a project for us to work on please contact us.

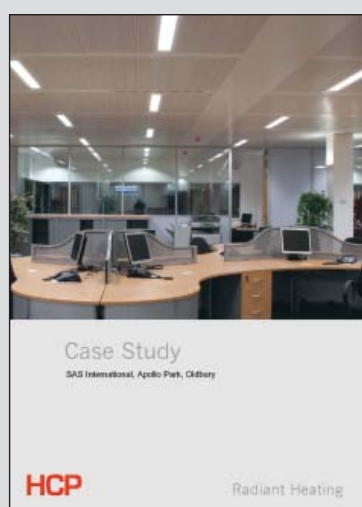

## CPD Success Continues



There is still huge demand for SAS CPD presentations. In 2007 we conducted 15 presentations in 9 months to 170 construction professionals.

Year to date we have already completed **31 presentations, to 300 people!** We have just received accreditation from the RIAI (Royal Institute of Architects Ireland) to present to Irish specifiers and we have already finalised 6 presentations at CIBSE (Chartered Institute of Building Service Engineers) regional meetings for 2009.

# St Pancras International Station

## London

St Pancras International has now become London's Eurostar terminus. A landmark transformation of the Grade I Listed original station has been achieved. The building's interior has been fitted out so old meets new creating a stunning combination.

Working within the original station design, metal ceiling solutions and bespoke lighting rafts were supplied by SAS International for the fit-out.

The Undercroft, originally used to warehouse beer barrels, is a forest of cast-iron columns supporting a grid of wrought iron girders which stretch

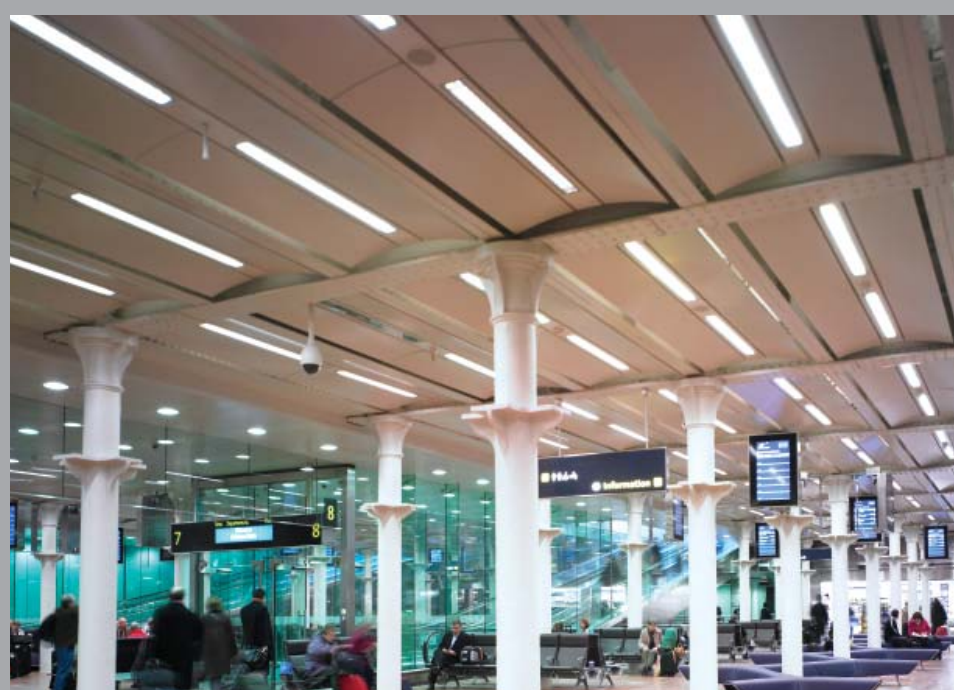
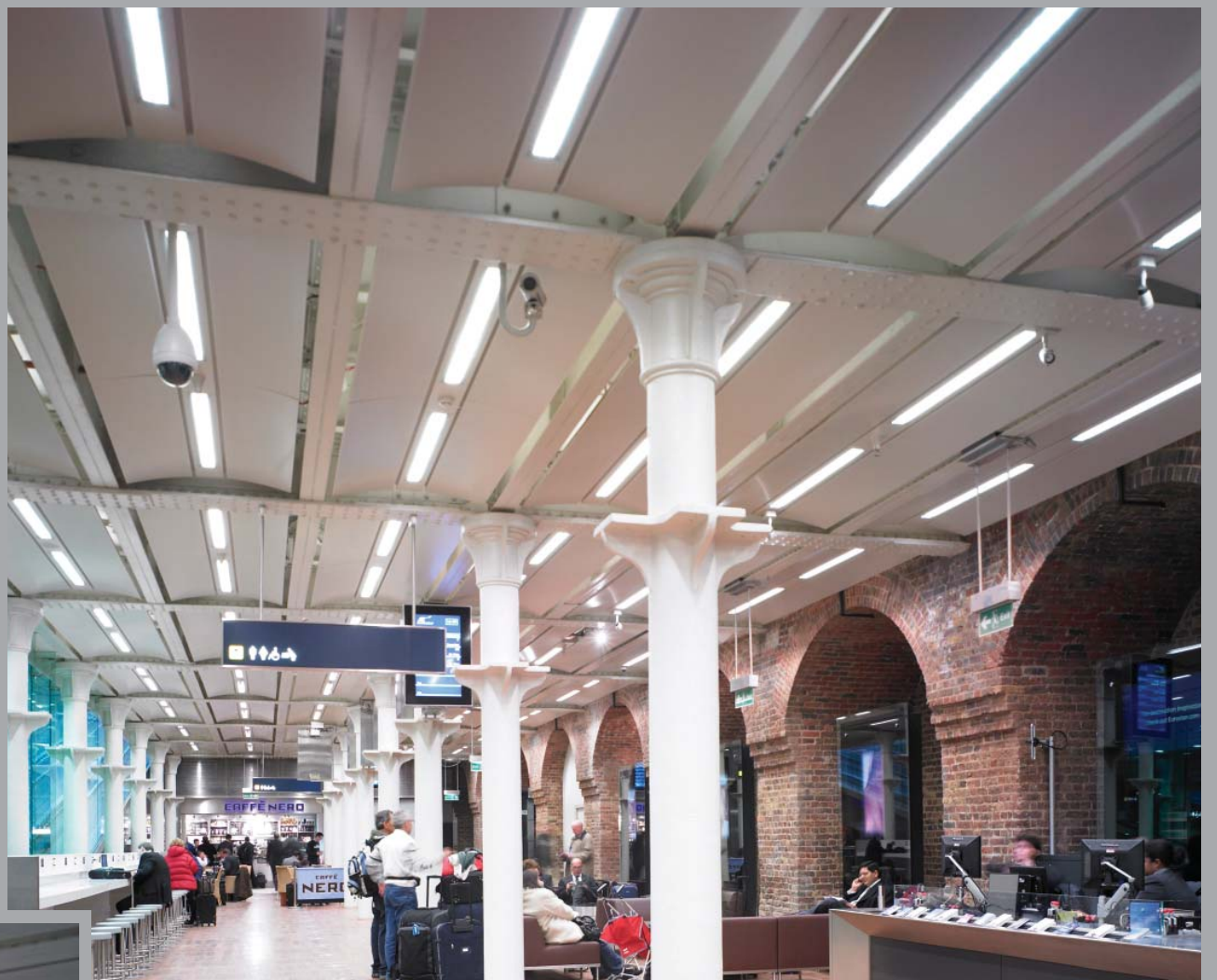

out in all directions; this space now houses retail units and the Eurostar departure and arrival areas.

Coffers are defined by exposed beam flanges, filled with curved ceiling height metal panels. These were a bespoke solution from SAS International incorporating luminaires. Panels provide swing down access to the services behind. The open space terminal is subject to external temperature changes, so the panels are manufactured from aluminium to provide long term durability.

Designed and specified by Alistair Lansley, London & Continental Railways' Chief architect, the bespoke panels complement the original beams and provide a practical modern look.

The Undercroft represented a key challenge when designing the ceiling solution as space height was restricted. This once dark space is now open and bright. Daylight has been channelled into the departure and arrival lounges by nine glass-sided slots containing travelators leading up to the platform. Above the travelators aluminium SAS System 330 suspended ceilings provide a clean, reflective, durable surface.

In other areas of the project, under the first level bridges and in the International departure area, SAS System 330 ceiling tiles were specified.

A robust aluminium solution, with ready-made apertures for luminaires, they add to the streamlined appearance that links re-fitted areas. The refurbishment has used a contemporary approach drawing on clear glass, polished steel and flush surfaces, for minimal visual intrusion in the Undercroft. The sleek appearance of the SAS metal ceiling systems perfectly complements this, whilst offering an easy to maintain solution.

LRC's Alistair Lansley's team of architects worked with a huge construction team on this £800m project, the main contractor was Corber (Costain, Laing O'Rourke, Bachy Soletanche and Emcor Rail).

Built in 1868 at the termination of the Midland Railway Company's new trunk route into London, the enormous iron and glass train shed was originally designed by the engineer William Henry Barlow. It became known as 'Barlow's Shed' and was so large, spanning 73m and standing 30m high, a record size held for 25 years. Now this London terminus houses the gateway to the UK's first high-speed rail line, cutting travel time to Paris to two and a quarter hours.

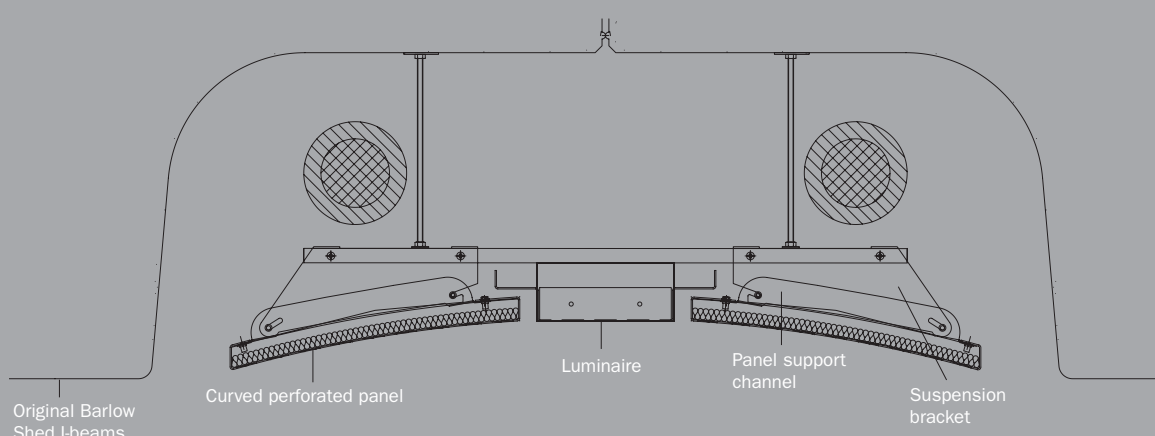

Case study available



## HCP Perimeter Heating unique specification

HCP have been traditionally known for their trench heating and more recently radiant ceiling panels. However, there are certain applications that require different HCP product solutions. When an infrastructure/transport project the size of the new St Pancras Station is refurbished the designs are often complicated and innovative. These are the kind of projects that all product manufacturers relish.

The perimeter heating is located around the station's nine travelators, which are a key feature in the station transporting passengers to and from the trains from departure and arrivals.

Perimeter heating has not been the most popular specified option for heating in buildings recently. With the advent of glazed facades in lobby areas and the 'minimalist' attitude to design, trench heating has been the most popular option.

Perimeter heating has also never been very architecturally attractive compared to some construction products. As a mechanical and electrical specified product many would argue that functionality is the most important criteria.

The travelators feature full-height glazing on both sides, which channels daylight downwards from the train shed, brightening up the once dark Undercroft area.

HCP supplied and installed approximately 300m of bespoke stainless steel perimeter heating.

The floor-mounted perimeter units run along the internal sides of the glazing, providing heating for occupant comfort and preventing the build up of condensation on the glazing.

Bolted to the floor the perimeter heating is located behind protective railings to prevent accidental damage from the thousands of daily passengers and their luggage. It was architecturally important as part of the specification that the heating units matched the brushed stainless steel sides of the travelators and the protective railings. They look striking beside the dark hardwood floor.

A project like St Pancras proves that perimeter heating is suitable for both new and refurbishment projects, it can be independently supported at low, medium or high levels to supply continuous heating and can meet stringent architectural specifications too.



Perimeter Heating

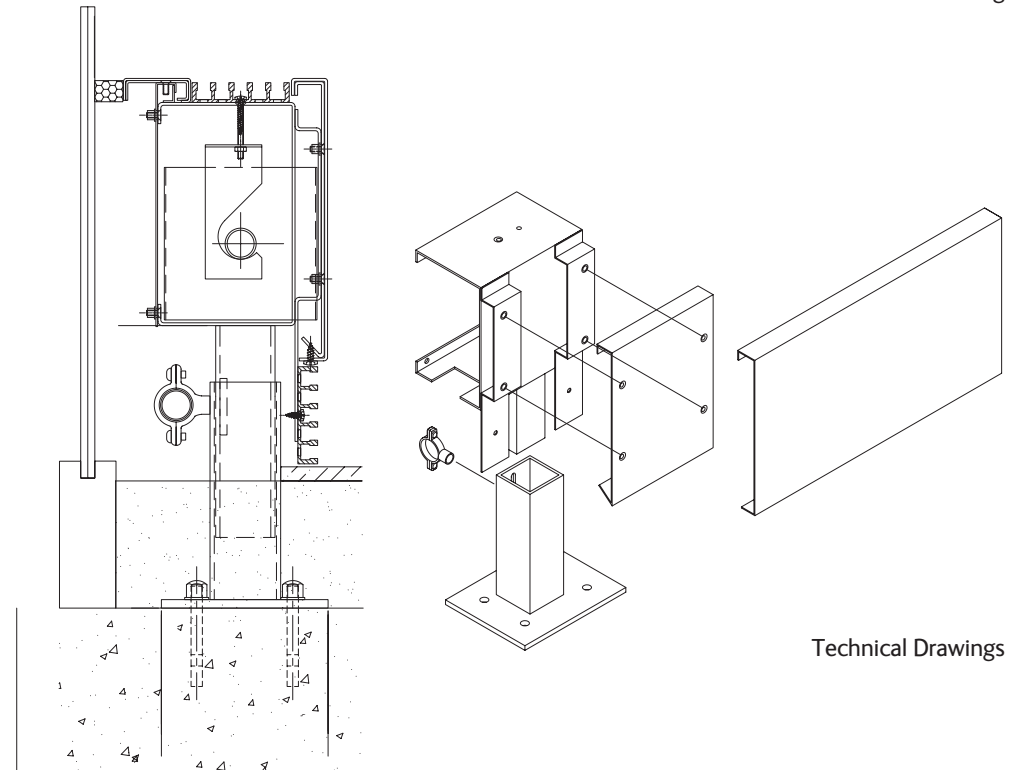

Technical Drawings

## A Day in the Life

HCP General Manager : Robin Dixon

I am married with 3 daughters aged 8, 5 and 2, and a dog Maisy, so totally outnumbered in our household! My daughters are the world to me, but as you can imagine can be handful with my youngest Leah at the terrible 2 stage, and my eldest Kiera aged 8 going on 16.

As most of those who do know me, apart from DIY, and what currently feels like landscape gardening, my other interests are cars and I have been a petrol head for my entire life, chopping and changing cars fairly frequently and often tinkering under the bonnet. Having a son might have been nice to share more bloke's interests, rather than a household which is a wash with prams and barbie dolls.

I have worked for HCP for 20 years, starting with HCP in a fairly junior position, and then worked in just about every section of the business over the years and continued to climb the ladder to General Manager.

My employment within HCP has been under various ownerships and demises and have seen HCP evolve and change considerably over the years. My various skill set and experience lends itself well to the General Manager role. It is rare that anyone can pull the wool over my eyes, and would like to think my experience gives a mutual respect with the 7 staff directly employed by HCP.

I live very local to my place of work, as all HCP staff do which is a benefit. However, it also has its pitfalls. Hours worked are officially 9-5 but are realistically the hours needed to get the job done.



*"HCP's continued evolution together with a market place that continues to develop keeps me on my toes and keeps the fire burning."*

In the summer months and on a good day, I can still be home to play with the kids in the garden and cut the grass whilst the sun is still shining. I am lucky enough due to my locality to work to be able to retain a reasonable work/life balance. But in the same token it's all too easy to pop into work late evenings or weekends to tie up some loose ends.

A directly employed workforce of 8 inclusive of myself, often means I am multi-tasking which can often be frustrating, there's never a dull day. Jumping between a sales role, to a 'no nonsense' contracts role within a 5 minute period is a bit of an art form.

My style of leadership is lead by example: Direct, hands on, friendly, and always trying to integrate with the team as much as possible. I aim to get to have relationships with staff where they can be confident to speak freely and honestly with me.

If times are good I am happy for all to share in a relaxed office, but when the chips are down I expect people to knuckle down, chip in, and go the extra mile.

HCP has been a huge part of my life, and often consider it as my 4th child. HCP's continued evolution together with a market place that continues to develop keeps me on my toes and keeps the fire burning.

I now find the industry becoming ever more confrontational, with money, and tighter deadlines making it very difficult to build relationships. It's a shame the emphasis seems to be going more away from just getting the job done, to spending more time covering basis/backside, to make sure you are actually rewarded with what's due. My quest is to change this, but it's a big industry with a lot of players.

**HCP**

# Avanti John completes Two Oceans Ultra Marathon

On Saturday 23rd March, after 6 months and over 1,100 miles of training, I lined up at the start of The Two Oceans Ultra Marathon. The event which is also known as the world's most Beautiful Marathon took place in Cape Town over a 35 mile hilly course.

Beginning 6.20am, just before sunrise, the start was extremely atmospheric with over 6000 runners from 37 countries nervously listening to Zulu war chants over the loudspeakers.

The first 14 miles of the race were fairly flat and allowed you to get into a comfortable pace and passed fairly quickly. After the 14 mile mark the course started to climb gently until the 16 mile mark where the first serious hill/mountain began. This was the 4 mile climb up to Chapman's Peak which rubber stamped why it was called the world's most beautiful marathon with scenic views over two glorious sandy bays. We were aided up the climb by various refreshments stops.

After the slightly easier descent from Chapman's Peak I met up with my family at the 24 mile mark which was good for



additional provisions and moral support before heading off for the final 11 miles. I went through marathon distance (26.2m) at 4hrs and 1 second, I really should have sprinted to get under 4hrs!

At 28 miles came to the steepest hill of the race which was the 2 mile climb up Constantia Nek, surprisingly I managed this with relatively little discomfort and after passing through the tunnel of cheering supporters at the top knew that I would definitely finish. I'm pleased to say I finished in 5hrs 26min which was inside my targeted time of 5hrs 30min.

The event was incredibly well supported, with energy drinks, bananas, boiled potatoes and even ice cream available on route to help you on your way. At strategic points there were also massage stations to

help ease tired legs. I'll admit to using all of the above in my attempt to complete the course in a reasonable state.

The Two Oceans was followed up 3 weeks later on the 13th April with our own London Marathon which I completed in 3hrs 31min.

By completing the 2 runs I have managed to raise approx £1,600 for Action Medical Research who Avanti have also supported through our charity golf days. For the rest of the year I plan to take it a little easier and try my hand at triathlon, cumulating in a 70.3 mile Ironman triathlon in September.



John Birken

## ...SAS Tee Grid Continued

As Bridgend has expanded to include additional factory space the roll forming lines were installed and commissioned.

As you can see by these pictures grid is available in both butt cutt and joggled end details and comes with the SAS logo embossed on to the product. SAS "International" White Tee Grid is targeting the mineral fibre market. The brochure is available now.

For more information please contact Hannah Faithful.



## 2008 Reading Carnival

SAS Reading has supported the Reading Community Carnival now for 3 years.

Again the year the 26 tonne lorry became a float through the streets of West Reading with Alan Excell at the wheel.

Even with the rain the day was enjoyed by all participants and spectators.

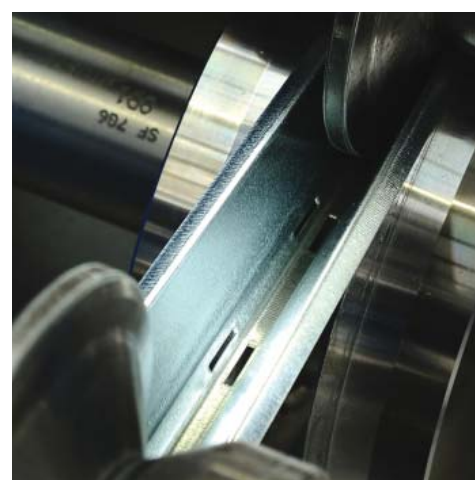
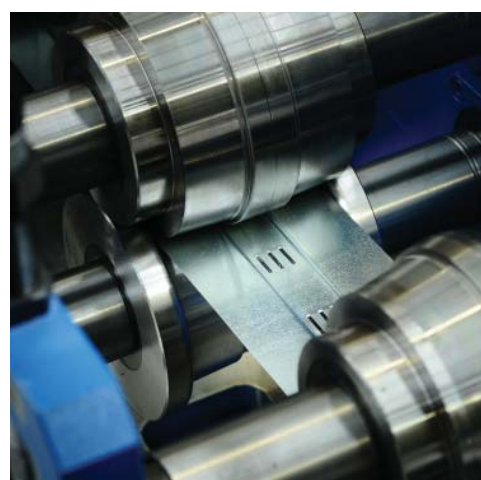

# Porsche Supercup 2008

# Team SAS



## TEAM SAS Lechner Racing Winners in Bahrain

SAS Lechner Racing had a great start into the 2008 Porsche Supercup season with Irishman Damien Faulkner winning the first race in Bahrain in an impressive way. Starting from second on the grid, he took the lead as pole sitter René Rast had to a technical problem. Faulkner took the lead and defended it to the finish, extending it to over seven seconds.

Walter Lechner Team Principal said "I am very pleased, it was a perfect start for us together with our new sponsor SAS International, who have a lot of guests here, who are all very happy now. They wanted to be associated with a winning team - now they are!

Damien had a fantastic race with his start-finish win, he was never challenged at all, while he had a bit of help from Jeroen Bleekemolen holding up everybody behind him."



Danny Watts, the second SAS Lechner Racing driver, was concerned, Lechner was more or less content: "I told him if he comes in within the top five, I would be happy - well, he made it sixth in the end. He did one move against Mamerow which he probably should not have done, that cost him a bit as he damaged his car slightly and and lost out towards the end."

The Sunday grid for the second Supercup race of the weekend was determined on Saturday's second fastest times. With Damien and Danny starting 5th and 6th on the grid it was always going to be hard to be in contention for the podium. Danny made a terrific start in the race picking his way through the field and coming round the second corner side by side with Damien.

A hard race meant Damien and Danny finished in 10th and 7th respectively.

### Barcelona

It was not the most successful of all racing weekends for SAS Lechner Racing at the Circuit de Catalunya, In qualifying Damien Faulkner only managed to qualify 12th on the grid. "You can't expect any wonders from there, especially not on this track where overtaking is very difficult", Team principal Walter Lechner admitted after Faulkner finishing the race in ninth place.

It was up to Danny Watts to save the honour for the team. he already lost two places at the start from his fourth position on the grid, which he never managed to recover during the race. So it's not only about qualifying, you also have to have a really good start if you want to fight for the podium.

### Istanbul

Damien and Danny both SAS Lechner Racing managed to finish fifth and seventh after some serious fighting. Qualifying 4th and 5th on the grid, Damien and Danny's race was full of some very hard wheel-to-wheel fighting. Faulkner dropped down to ninth in a very close group of competitors in the early stages of the race, Watts had his big chance just minutes later. Fighting with René Rast, both cars touched and



while Watts was able to continue with slight damage, it meant the end of the race for Rast. Although bad luck for others Damien was able to capitalise.



He took advantage of the chaos, climbing back to fifth by the chequered flag. Watts did a good job in bringing home his slightly bent and bruised GT3 997 in seventh position.

### Monaco

Great finish for SAS Lechner Racing at the fifth race at Monaco: Damien got a well deserved podium finish by ending the race in second position. Danny had to put up with 19th place after a few mistakes.

Damien did very well in qualifying, missing pole position by only by a tenth of a second. Due to heavy rain the race was started behind the safety car, and taking into consideration the special Monaco conditions, where overtaking without risking a crash is nearly impossible, it was not a big surprise that Faulkner, even being visibly faster, had no chance of getting by pole sitter and later winner Jeroen Bleekemolen.

Danny Watts missed out on points after a slight mistake under braking. This cost him dearly: Dropping from 14th on the grid he managed to bring the car home in 19th position.

## 2008 Race Season Results

6 April	Bahrain Round 1	Damien 1st Danny 6th
	Bahrain Round 2	Damien 10th Danny 7th
27 April	Barcelona Round 3	Damien 9th Danny 6th
11 May	Istanbul Round 4	Damien 5th Danny 7th
25 May	Monaco Round 5	Damien Faulkner 2nd Danny Watts 19th
22 June	France	Magny Cours
06 July	Britain	Silverstone
20 July	Germany	Hockenheim
03 August	Hungary	Hungaroring
24 August	Europe	Valencia (New Race)
07 September	Belgium	Spa
14 September	Italy	Monza





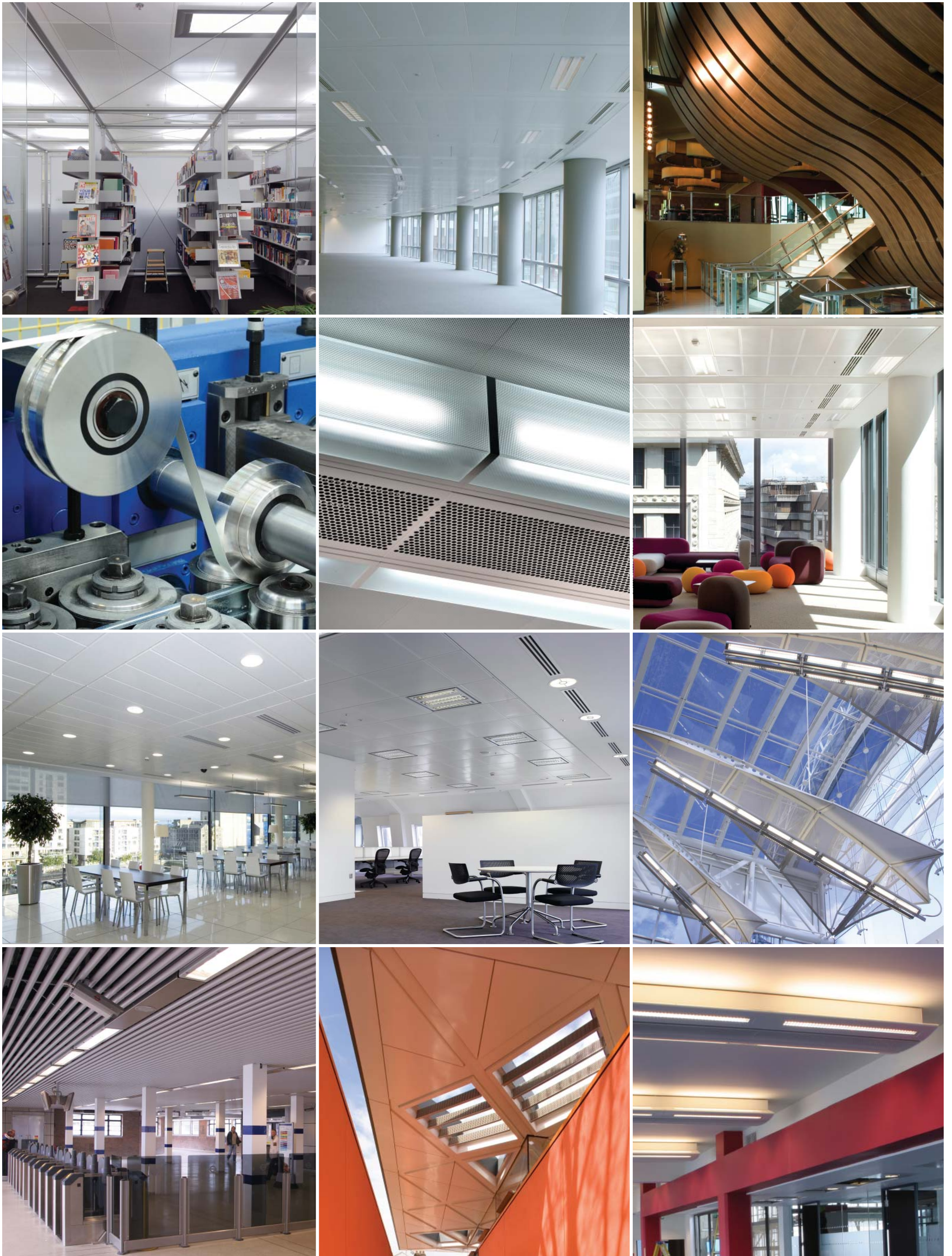

**Top Left to Right:** Creo Project, Tel Aviv, Israel · Batiment B, Paris · Alea Casino, Glasgow · **Second Row Left to Right:** Bridgend Factory, SAS Tee Grid · Active ISM Mock up · Unilever House, London **Third Row Left to Right:** Accenture, Dublin · Condor House, St Pauls Churchyard, London · M&S Cribbs Causeway, Bristol · **Fourth Row Left to Right:** LUL Wembley Park, London · Maggie's Centre, Hammersmith · Kings College, London.

# The SAS Working Family: Bridgend

Over the past few years the staff levels across all SAS facilities have slowly risen as the company expands. We thought it would be interesting to see how many families work within SAS. For each 2008 Issue of the Insider we will focus on a SAS location and outline the related employees. There are certainly more than you think.

Family Members	Relationship(s)
Eddie McElhinney (CEO) Mark McElhinney (Managing Director)	Father & Son
Julia Davies (Group HR Manager) Zaac Entwistle (Line Leader, Assembly)	Mother & Son
Darren Rossiter (Materials Handler) Helen Rossiter (Line Setter, Padshop)	Husband & Wife
John Callard (Materials Handler) Diane Callard (Paint Readings)	Husband & Wife
Marvin Symonds (Paint Plant Operator) Richard Symonds (Production Operator, Assembly)	Father & Son
Roger Williams (Production Operator, Padshop) Robert Williams (Production Operator, Padshop)	Brothers
Paul Bowden (Shift Supervisor, Padshop) Robert Bowden (Production Operator)	Father & Son
Konrad Gluszczyk (Operator, Padshop) Krzysztof Gluszczyk (Operator Carpentry)	Cousins
Mark Maiden (Plasterboard), Neil Maiden (Padshop) Dai maiden (Line Leader)	Brothers
Adrian & Krzysztof Zygmunt (Operators, Assembly)	Brothers
Artur Buszkiewicz (Operator, Paintline) Jacek Buszkiewicz (Operator, Assembly)	Brothers
Wiktor Augustyn (Operator, Padshop) Joanna Augustyn (Operator, Assembly)	Brother & Sister
Sean Lowe (Line Leader, Padshop) Richard Evans (Operator, Assembly)	Cousins
Denzil Beckey (Carpenter) Archie & Arnie Tolentino (Operators)	Father & Sons
Les Bissmire (Press Operator) Stephen & Thomas Bissmire (Operators)	Father & Sons
Kerry Richards & Paul Richards (Operators, Paintline)	Mother & Son
Mark Cumbes & Scott Cumbes (MS)	Father & Son
Jacobus & Nadia Vermeulen (MS)	Husband & Wife

## Apollo Park Retirement

Rupert Ebanks will be retiring from SAS Apollo Park on the 24th July 2008 this year.

Rupert started work at SAS West Bromwich on 22nd July 1984.

He currently works in the Open Cell Department as an assembler.

We would like to thank Rupert for his contribution over the last 24 years and wish him all the best future and his retirement.

## SAS Lunch Bar

At SAS Reading there had long been great anticipation in the office around 10:45/11am time. Phones used to ring and if you were lucky (and near a window) you would hear the horn of the sandwich van. The rush would then take place to get to the van for the best choice of baguette.

With increased staff at the Reading office (including the Modular Solutions division) the demand on sandwich vans were huge. In answer to the growing numbers of staff SAS run a Lunch Bar where staff can get food till midday everyday. Run by Diane and her daughter Jane Dunne both ex SAS / CCF canteen staff. The demand for some home cooked food is huge and the non-profit lunch service has increased the standard and access to good food for all.



Diane West & her daughter Jane Dunne

## English Lessons for Bridgend Staff

Polish, Iraqi and Lithuanian staff from the Bridgend factory have recently completed an English language course. The eleven week course was provided by local teacher Jenny Sen of Bridgend College. The course took working in a factory environment into consideration.

Fifteen students recorded a 100% attendance level for the duration of the course. Held every Tuesday, the course proved very popular with all students improving their communication skills. The company is currently gathering feedback and looking at the provision of further English classes.

English Students were:

Level 1: Badr D El Bahri, Alina Kubica, Tarik Mohamad, Justyna Lampka, Ewelina Skalinska, Robert Wozniak and Adrian Zygmunt.

Level 2: Valentinas Avdejevas, Krzysztof Gluszczyk, Kamila Kropidlowska, Piotr Orzakiewicz, Piotr Kwiatkowski, Maciej Pacyna, Albert Siekiera & Krzysztof Zygmunt.



## Insider on Tour

We know the Insider is requested by various construction disciplines around the construction industry and within SAS each quarter. However, we want to find out how far the Insider gets on its travels please email us a picture of the Insider out and about.

John Staunton has recently been to Ireland and not only took the Insider with him but also took a picture of it!



# Meet: The SAS Irish Team

## Q&A

**How did you end up working at SAS and what is your current role ?**

**The best thing about working at SAS ?**

**And the worst ?**

**If you could change one thing about working at SAS what would it be ?**

**First job ?**

**Hobbies ?**

**Your proudest achievement and why ?**

**What is your favourite music ?**

**Favourite food ?**

Cathal McGuinness



I moved to England in 1990, had an interview with EME on a Sunday morning in Victoria Station and started work on the Monday as a Junior Designer (MAJ was my Design Manager). I'm currently the Irish General Manager looking after all things Irish.

The challenge and being best at what we do.

It puts years on you!

For everyone to experience selling, the thrill of winning and to have the determination and passion to fulfil what you have just sold.

Working in a fish factory for my summer holidays (age 12)

Playing guitar, golf and sailing

Being blessed with 2 daughters and hopefully they will look after me when I'm old and completely bald

The Frames, Tom Waits, John Prine, Van Morrison ect ect

Chilly & Garlic prawns served with spaghetti and fresh rocket and a squeeze of lemon.

Eliot Noble



I worked for HCP from November 89 which was later acquired by SAS. I decided to move to Ireland to live with my girlfriend (Now Wife) and an opportunity of SAS Ireland presented itself. My Role is Export Sales Coordinator amongst various others.

Never a dull moment / continual employment.

Never getting an uninterrupted lunch break.

I would just like to get uninterrupted lunch breaks. In fact a lunch break would be nice.

Ice cream maker (Proper Ice cream – not that Mr. Whippy stuff)

Mountain Biking, Pool, Photography & Walking my Boerboel Dog along Balbriggan's varied coastline.

Making it to age 37 (3 near misses along the way) However my proudest achievement ever is becoming a dad.

Depeche Mode, Beck, Gorillaz, White Zombie, Nick Cave, Red Hot Chilli Peppers, & Sinatra (Quite varied as you can see).

Chinese and Italian food. Also good home cooked stews and soups.

Richard Bryant



I was asked to rejoin the SAS export sales team – I spend much of my time working with Irish architects and generating specifications but still also manage a portfolio of projects in other countries.

Working on interesting projects and my colleagues.

Parking at Reading – if you park/work in Reading you'll think that too!

The yearly holiday allowance could be increased by a few days

Worked at a Go-Karting track in Reading – brilliant job!

Watching newly relegated Reading FC and the famous "socialising"

Marrying my wife (And beating Chris Ellingham's record of making a sample pizza box in under 60 seconds)

Elvis, Coldplay and various dreadful tunes from the '80s

Curry – I could eat curry 7 days a week, 365 days a year for Breakfast lunch and Dinner

## SAS Brochure for Dublin

The Insider has been pro-active in reporting the development of our Irish office in previous issues.

In the coming weeks we will be sending the new SAS Irish Flyer to specifiers, engineers and contractors. It gives them an overview of the SAS International products and services that are available. If you require any additional information about our Irish office please contact marketing.

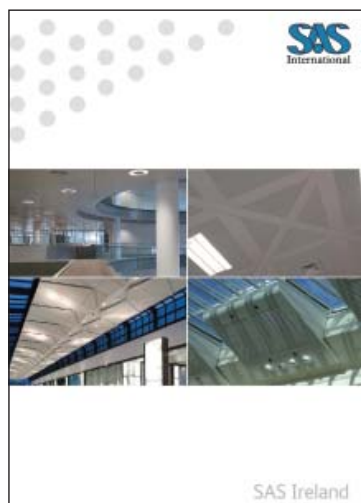

## Caption Competition Issue 7:

Duncan Wisely from SAS Project Management

Suggest what Duncan might be saying or a caption for the entire photo to win a special prize.

The best entries will be printed in the next issue. Send all entries to [sasinsider@sasint.co.uk](mailto:sasinsider@sasint.co.uk)



## Long Service Awards

2008 April - August

totalling a huge 135 years service between them..

Name	Location	Start Date	Service
David Fry	Reading	25/04/1998	10
John James	Bridgend	16/05/1988	20
Kathy Lewington	Reading	13/06/1983	25
Christine Thomas	Bridgend	06/07/1998	10
Jonathan Conn	Maybole	14/07/1998	10
Euron Jones	Bridgend	31/07/1998	10
Ian Chisolm	Maybole	01/08/1988	20
David McGregor	Maybole	09/08/1993	15
Ross Lippitt	Apollo Pk	13/08/1993	15

## Results of Issue 6 Caption Competition:



"Steve, do you think this is a good idea? Some plonker will probably use the picture for a caption competition".

The winner of the last caption contest is none other than the star of the picture Mark Glead from Project Management. He wins the toy man USB stick.



# Charlestown Mall

## Dublin

Architectural metalwork solutions from SAS International were chosen for a recently completed €140 million shopping centre near Dublin. Designed by HKR Architects, the shopping mall includes 24 double height retail units, and features a high design specification.

SAS International was asked by the architects to work with them to create a bespoke solution for the ceilings in the central walkway of the Mall, utilising the SAS in house design team. The result is striking; a feature suspended ceiling floats down the length of the walkway, with three dimensional metal 'kites' protruding along its length.

Manufactured from triangular panels, the installation has the appearance of a central spine, while integrating luminaires, IT and security equipment.

"Charlestown provides a quality retailing experience," says Phillip Taylor from HKR Architects.



"We worked with SAS International to provide a metal ceiling solution which offers a robust option that is easy to maintain, but we have also created a unique design that fitted perfectly into our vision for the interior environment," added Hendrik Mueller, who also worked on the project.

The panels were perforated which allows for the light to shine through from above. With glazed panels on either side of the metalwork, the roof becomes an attractive design feature, open light and space helps make for a comfortable and attractive shopping experience.

Suspension components holding the white suspended metalwork add to the feeling that it is floating.

Similar metal triangular formation panel designs from SAS International feature in the ceilings above the side malls, but suspended in horizontal 'bands' which create a feeling of increased breadth in the space.

Stretching design, manufacturing parameters and processes are demonstrated through SAS International's architectural metalwork. Adding to the immediate environment or making a statement, architectural metalwork solutions provide huge flexibility as well as practical options that are fit for purpose.

SAS International's dedicated Dublin office has completed a number of architectural metalwork projects across Ireland including; column casings and spandrel panels at Riverside One, Dublin; acoustic lighting rafts for the Commissionaire of Irish Lights, Dublin and air handlings units at Mahon Point, Cork.

### Key Facts:

- During construction 10,000 tonnes of environmentally friendly cement was used, saving 9,000 tonnes of CO2, that is equivalent of taking 2,200 cars off the road for one year.
- Charlestown has its own energy efficient Central Energy Centre. The Carbon footprint of the centre is so low that no carbon taxes apply through the site.
- 97% of waste generated in the centre has been recycled since opening. Making it the industry leader for recycling.
- Planning permission has just been granted for Phase 2, this is an additional 37,000 square meters of retail space over eight buildings.

### Case study available



architectural metalwork



The SAS Insider welcomes news and comments from everyone at SAS International, HCP and Avanti Systems. Please email [sasinsider@sasint.co.uk](mailto:sasinsider@sasint.co.uk). Contact Andrea Nightingale on 0118 929 0900 or any member of the marketing team. Written & Produced by the SAS Marketing team.

SAS International 31 Suttons Business Park, London Road, Reading, Berkshire, RG6 1AZ, United Kingdom. T: +44 (0) 118 929 0900 F: +44 (0) 118 929 0901 W: [www.sasint.co.uk](http://www.sasint.co.uk)

\* FSC certified Paper - Printed using vegetable based inks on paper produced from sustainable and well managed forests. Our printer holds the environmental standard ISO 14001.